



EURO 76 Installation Guide

System Overview

| System Overview | EURO 76 | Additional Information |
|-------------------|---------|---|
| Areas | | |
| Independent areas | 6 | |
| Wards | 5 | Each ward is created by a proximity reader |
| Inputs | | |
| On board | 8 | Supports N/C, 3EOL, DEOL and SEOL |
| Wireless | 64 | Requires 2 x EURO-ZEM32-WE |
| Maximum | 76 | Refer to 'Input Mapping' table |
| Outputs | | |
| PCB | 5 | 1 Relay, 4 transistor (inputs 7 & 8 may be used as outputs) |
| ATE | 10 | Low power ATE outputs |
| Maximum | 85 | Refer to 'Output Mapping' table |
| User automation | 20 | Outputs programmed to activate on user command |

| | | |
|-------------------|--|--|
| user automation | 30 | Outputs programmed to activate on user command |
| Users | | |
| Users | 75 | |
| Wireless key fobs | 32 | Requires 1 x EURO-ZEM32-WE |
| Guard/duress | 10 | |
| Engineer | 1 | |
| Maximum | 87 | Including Master Code and wireless key fobs |
| Arming Devices | | |
| Wired | 6 | Keypads and proximity readers |
| Wireless | 4 | Requires 1 x EURO-ZEM32-WE |
| Communication | | |
| Compatible modems | PSTN, PSTN/VOICE, GSM, GPRS, Wi-Fi/XA and LAN | |
| ARC formats | Contact ID, Fast Format and SIA3 (also IP variants in all 3) | |
| | | |

| | | | | |
|---------------------------|------------|--|------------------------------------|-------------------|
| User formats | | Push notifications, SMS messaging and Voice messaging. | | |
| Phone numbers | | 10 | Used for SMS messaging | |
| UDL Support | | Yes | Using the upload/download software | |
| Logs | | | | |
| Memory | | 1250 | Memory type is EEPROM | |
| Dimensions and Compliance | | | | |
| Dimensions (H x W x D) | Small Case | 297 x 250 x 82 mm | PCB | 110 x 170 x 40 mm |
| | Large Case | 390 x 305 x 100 mm | | |
| EN grading | | 2 (small metal) 3 (large metal) | | |
| Environmental class | | II | | |



Default codes

| | | |
|----------------|------|--|
| Engineer | 1111 | |
| Master Manager | 2222 | |

Input Mapping

| Devices | Address | Input Numbers |
|--|---------|---------------|
| EURO 76 PCB | N/A | 1-8 |
| EURO-ZEM8 / EURO-ZEM8+ / EURO-ZEM8+PSU / EURO-ZEM32-WE | 0 | 9-16 |
| EURO-ZEM8 / EURO-ZEM8+ / EURO-ZEM8+PSU / EURO-ZEM32-WE | 1 | 17-24 |
| EURO-ZEM8 / EURO-ZEM8+ / EURO-ZEM8+PSU / EURO-ZEM32-WE | 2 | 25-32 |
| EURO-ZEM8 / EURO-ZEM8+ / EURO-ZEM8+PSU / EURO-ZEM32-WE | 3 | 33-40 |
| EURO-ZEM8 / EURO-ZEM8+ / EURO-ZEM8+PSU / EURO-ZEM32-WE | 4 | 41-48 |
| EURO-ZEM8 / EURO-ZEM8+ / EURO-ZEM8+PSU / EURO-ZEM32-WE | 5 | 49-56 |
| EURO-ZEM8 / EURO-ZEM8+ / EURO-ZEM8+PSU / EURO-ZEM32-WE | 6 | 57-64 |
| EURO-ZEM8 / EURO-ZEM8+ / EURO-ZEM8+PSU / EURO-ZEM32-WE | 7 | 65-72 |
| EURO-LCD/EX | 0 | 73-74 |
| EURO-LCD/EX / EURO-PROX/INT | 1 | 75-76 |
| TOTAL | | 76 |



Output Mapping

| Devices | Address | Outputs Numbers |
|---|---------|-----------------|
| EURO 76 PCB | N/A | 5 (2 shared) |
| Digi/ATE Outputs (using communication loom) | N/A | 10 |
| EURO-OEM8R8T / EURO-OEM16R+PSU | 0 | 1-16 |
| EURO-OEM8R8T / EURO-OEM16R+PSU | 1 | 17-32 |
| EURO-ZEM8+ / EURO-ZEM8+PSU | 0 | 1-4 |
| EURO-ZEM8+ / EURO-ZEM8+PSU | 1 | 1-4 |
| EURO-ZEM8+ / EURO-ZEM8+PSU | 2 | 1-4 |
| EURO-ZEM8+ / EURO-ZEM8+PSU | 3 | 1-4 |
| EURO-ZEM8+ / EURO-ZEM8+PSU | 4 | 1-4 |
| EURO-ZEM8+ / EURO-ZEM8+PSU | 5 | 1-4 |
| EURO-ZEM8+ / EURO-ZEM8+PSU | 6 | 1-4 |
| EURO-ZEM8+ / EURO-ZEM8+PSU | 7 | 1-4 |

| | | |
|---|---|----|
| EURO-LCD/EX | 0 | 1 |
| EURO-LCD/EX / EURO-PROX/INT / EURO-EXT-BK/W | 1 | 1 |
| EURO-LCD/EX / EURO-PROX/INT / EURO-EXT-BK/W | 2 | 1 |
| EURO-LCD/EX / EURO-PROX/INT / EURO-EXT-BK/W | 3 | 1 |
| EURO-LCD/EX / EURO-PROX/INT / EURO-EXT-BK/W | 4 | 1 |
| EURO-LCD/EX / EURO-PROX/INT / EURO-EXT-BK/W | 5 | 1 |
| Total | | 85 |

Regulatory Wiring Requirements

- Ensure wiring is done to the national wiring regulations in the country where the installation is taking place. In the UK, this is BS 7671 Requirements for electrical installations; IET Wiring Regulations (17th edition). If in doubt, consult a local qualified electrician.
- Ensure that a readily accessible disconnect device incorporated in the premises installation wiring shall be provided external to the equipment with a contact separation of at least 3,0mm and connected as closely as possible to the supply. Example: Fused Spur Unit
- When fixing external wires, ensure that means are provided in the installation to prevent the SELV (Safety Electrical Low Voltage) or signal circuits from coming into contact with live parts of the

power supply circuit. Wires shall be fixed near their terminal blocks.

- The end of stranded conductor shall not be consolidated by soft soldering at places where the conductor is subjected to contact pressure. Example: Must not solder ends of wires which are to be secured in detector and control panel terminal connectors.
- On completion of wiring use tie-wraps to prevent any loose wires causing a safety hazard (material of cables tie shall be rated at least HB or better).
- Cables ties and sleeves shall be separate for power supply cable and SELV (Safety Electrical Low Voltage) wirings.
- Size of protective bonding conductors: minimum section 1.5mm^2 . Example: Electrical Earth wire connections.

Technical Specification

| Programming Outputs | Power Rating | Normal State | Active State |
|---------------------|--------------------|--------------------|-------------------------------------|
| PGM 1 | Relay, 3A, max 30V | Changeover NC & NO | Changeover NC & NO |
| Speaker | 16 ohms | No tones | Repeat RKP tones & internal sounder |
| Strobe output | 500mA | 12v | 0v |
| Bell output | 500mA | 12v | 0v |
| XPGM 1 (Input 7) | 50mA | Floating | 0v |
| XPGM 2 (Input 8) | 50mA | Floating | 0v |
| ATE outputs | 2mA | 5v | 0v |
| Circuit States | Resistance Range | | |
| | 1k / 1k Range | 4k7 / 2k2 Range | 4k7 / 4k7 Range |
| Normal | 0k5 to 1k4 | 1k4 to 2k9 | 3k7 to 8k3 |
| Alarm | 1k5 to 5k9 | 4k2 to 7k8 | 8k4 to 10k2 |
| Fault | 6k to 8k1 | 8k to 11k3 | 10k3 to 14k9 |

| | | | |
|-------------------------------------|--------------|------------------------------------|------------------------------------|
| Masking | 8k2 to 17k | 11k6 to 22k | 15k to 22k |
| Tamper | <0k5 or >17k | <1k4 or >22k | <3k7 or >22k |
| Fuses | | Value | Type |
| Bell fuse for bell terminals | | F800mA quick blow 250V | Glass |
| Aux fuse for aux terminals | | F800mA quick blow 250V | Glass |
| RS485 bus fuse for bus terminals | | F800mA quick blow 250V | Glass |
| Battery fuse for battery terminals | | T 1.5A anti-surge slow blow 250V | Glass |
| 230V mains fuse for mains terminals | | T500mA H anti-surge slow blow 250V | Ceramic |
| Panel Power Supply Output | | Nominal | Range |
| Output voltage | | ~13.7VDC | ~10-15VDC |
| Output current | Small Metal | 1A Continuous | 1.5A peak, during battery charging |
| | Large Metal | 1.5A Continuous | 2.0A peak, during battery charging |
| | | | |

| Panel Power Supply Input | | Nominal | Range |
|--------------------------|-------------|-----------------|---------------|
| Mains supply voltage AC | | 230 VAC at 50Hz | -15% +10 % |
| Transformer rating | Small metal | 18VA | 18V at 1.0A |
| | Large metal | 45VA | 18.5V at 2.5A |

Power Supply Type A.

Maximum output peak voltage: Max 100 mV

SD Voltage which the deep discharge protection function will operate at: 10V

Over Voltage Protection Trigger Voltage: 18V

Battery Charging Specification

| | | | |
|-----------------------------|---------|----------------------------------|-------------------|
| Float voltage | 13.8VDC | Recharge time | <24 hours |
| Battery low voltage cut off | 10.5V | Standby battery capacity current | 300mA (3A to 6A) |
| | | | 700mA (7A to 17A) |

PLEASE NOTE: EURO 76 power supplies are NOT designed for use with multiple batteries connected. System load should not exceed the panel power supply output shown above, or the maximum load supportable by the battery for the specified backup time, as in the table shown below.

The power ratings are based on battery shown in table – but battery capable of supporting the system load for the required time may be used without affecting these ratings.

EN50131-6:2008 Rated Output

In accordance with EN50131-6:2008, the EURO standby times and effective output currents depend on the Security Grade of the system and how missing fault is signalled to the Alarm Receiving Centre. Power supplies are rated in accordance with the requirements of EN50131-6, which are related to the maximum battery size that can be accommodated in the housing and vary according to the grade of the system in which they are installed, as per the following table:

| Electrical Capability | | EN50131-6 Rating. Maximum Load | |
|---------------------------------|---------|--------------------------------|--------------|
| Example Battery Model | | Grade 2 | Grade 1 |
| Yuasa NP7-12 | | 0.5A | 0.3A |
| Yuasa NP17-12 | | 1.2A | 0.7A |
| EURO 76 PCB Current Consumption | | Environmental | |
| Quiescent | 80mA | Operational | -10°C Cer |
| User Code and Tag Guessing | | Storage | -20°C |
| 4-digit codes | 10,000 | Humidity | 75% |
| 6-digit codes | 100,000 | Dimensions | |

| | | | | |
|---|------|--|-----------------|--------|
| Disallowed codes | None | | | 250 |
| | | | Metal case | We bat |
| All codes | 1612 | | | 390 |
| | | | | We bat |
| According to EN50131-3:2009 Annex B | | | PCB | 170 |
| According to spec of manufacturer of RFID components used | | | EN50131 Grading | 3 |

The below table specifies ATS (Alarm Transmission System) performance criteria in accordance with the requirements of EN50136-1.

| Notification Equipment | Grade 2 Criteria | | | | Grade |
|-----------------------------------|------------------|----------|----------|----------|----------|
| | Options | | | | Options |
| | A | B | C | D | A |
| Remotely powered external sounder | 2 | Optional | Optional | Optional | 2 |
| Self-powered external sounder | Optional | 1 | Optional | Optional | Optional |
| Main communication path (ATS) | ATS 2 | ATS 2 | ATS 2 | ATS 3 | ATS |
| Second communication path (ATS) | Optional | Optional | ATS 1 | Optional | Optional |

Out of the Box

Unscrew and remove the cover of the EURO 76 (Figure 1). The EURO 76 printed circuit board is located to the top right hand side. (Figure 2)

Install the supplied stand-offs if needed before mounting the metal case to the wall (Figure 3).

Connect any modems if required and any other devices (input expanders, output expanders etc.) before powering up the system.

Screw the back metal plate to the wall.

Wire the telephone line if the DIGI-1200 modem (PSTN) is installed or the LAN cable if the DIGI-LAN is installed.

Install the SIM card, connect the antenna and locate outside of the metal casing if the GPRS or Wi-Fi modem is used.

EURO 76: The tamper mechanism comes already fitted.

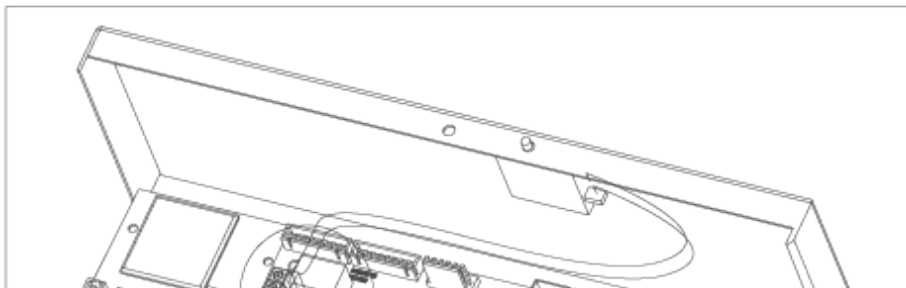

Figure 1

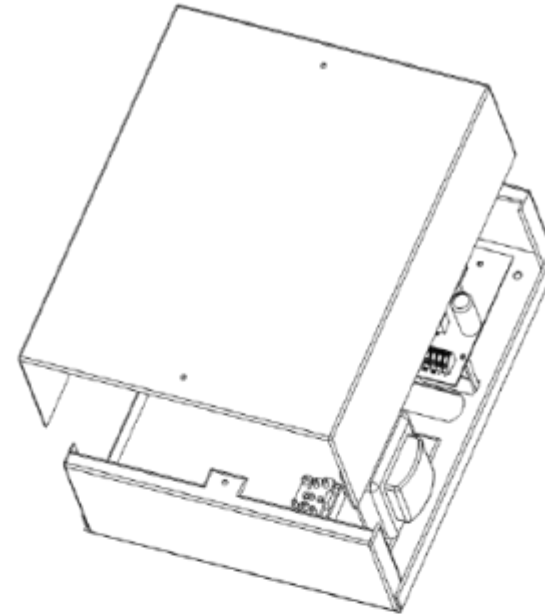

Figure 2

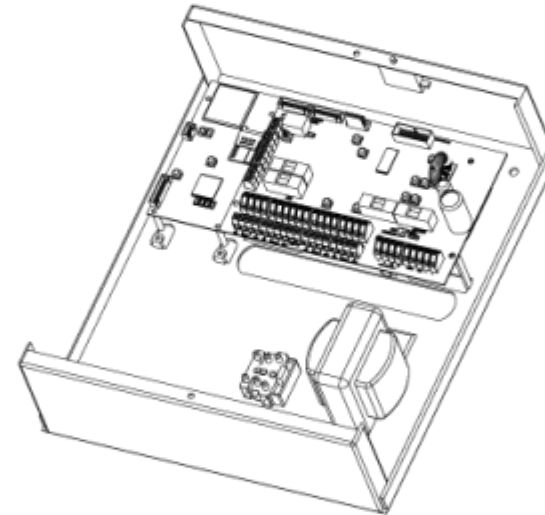
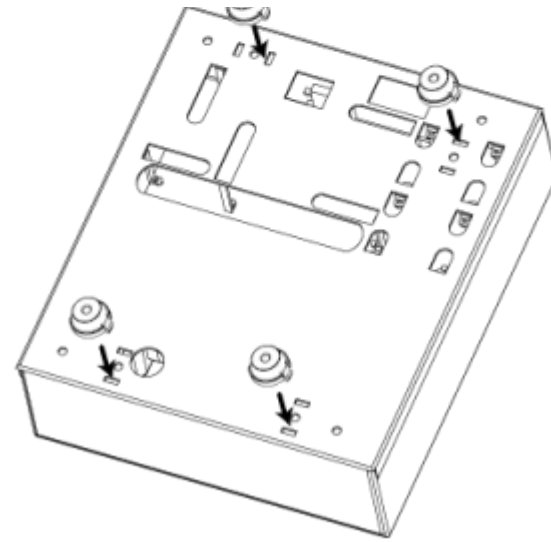

Figure 3



Secure all the wires and close the enclosure making sure the tamper is operational.

Turn on the power to the EURO 76.



On power up, the panel will typically show the below screens.



The Printed Circuit Board

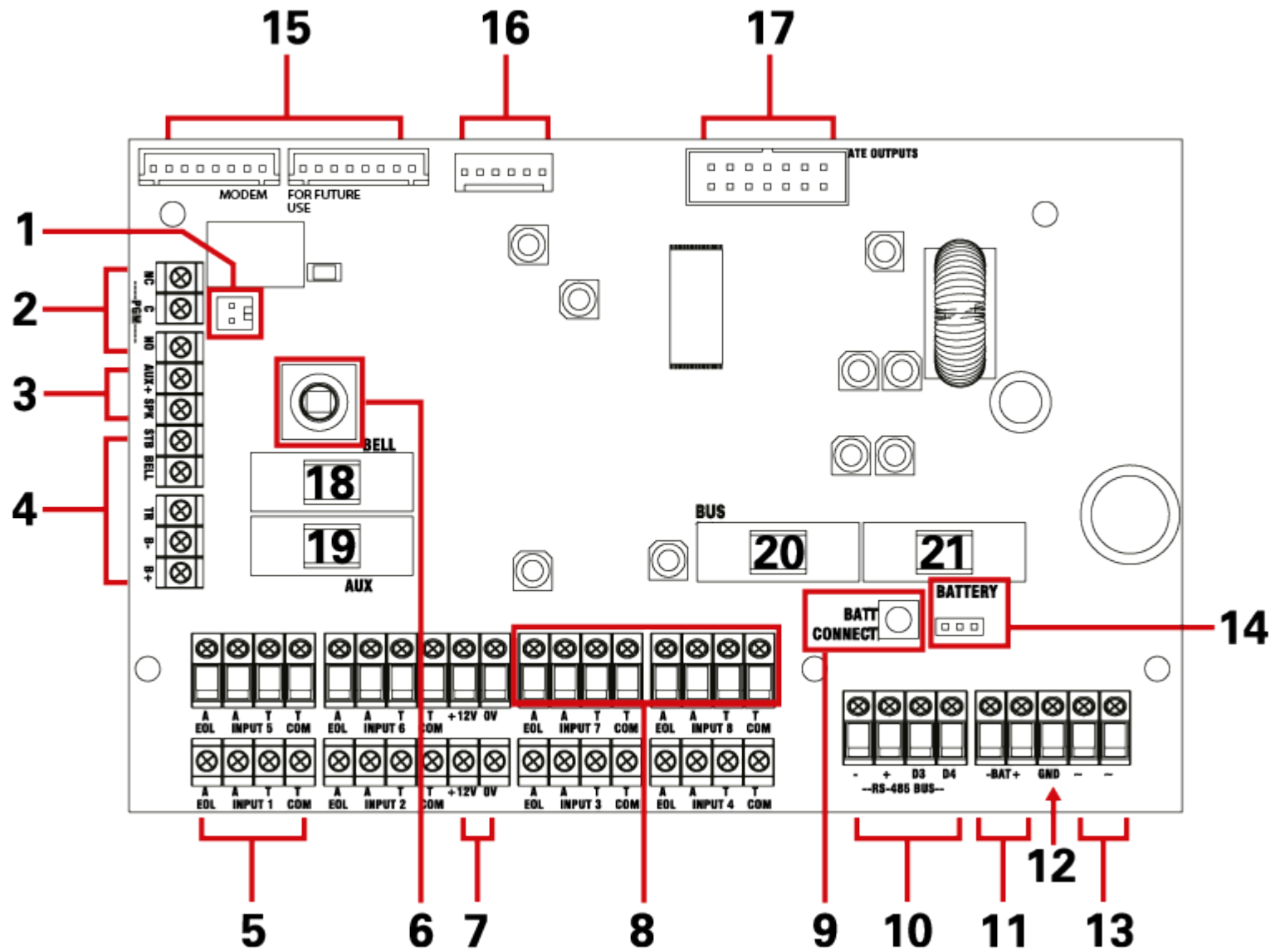

1: Case tamper 'Hold-Off' jumper

2: PGM 1

3: Speaker connection

Connects a 16ohm speaker.

4: External sounder connections

Connects an external sounder.

5: Input connections

8 Fully programmable inputs.

6: Tamper switch

Optional tamper protection for the metal casing.

7: Auxiliary 12V power

12V power supply

8: Inputs or outputs

Inputs 7 and 8 may be programmed as outputs if unused.

9: Battery connect 'Kick-start' switch

To power-up and program from battery power (when there is no mains power available).

10: RS485 bus terminals

Connects peripherals.

11: Battery connection

For battery back up.

12: Earth connection

Connects the earth.

13: 17V connection

Connects the AC transformer 17V supply.

14: Battery charge capacity jumper

For battery back up.

15: Modem connections

The left connector (labelled 'modem') is for signalling modems.

PLEASE NOTE: The right is 'For Future Use', please do not use.

16: RS232 Connection

This connection is used for an RS232 lead that will connect to a PC to allow uploading and downloading of data using the InSite software.

17: Communication Outputs

Connects the supplied communication loom to enable an additional 9 programmable outputs. These are low current and would normally be used when connecting a stand-alone communicator to the panel.

18: Bell Fuse

19: Auxiliary Fuse

20: Bus Fuse

21: Battery Fuse

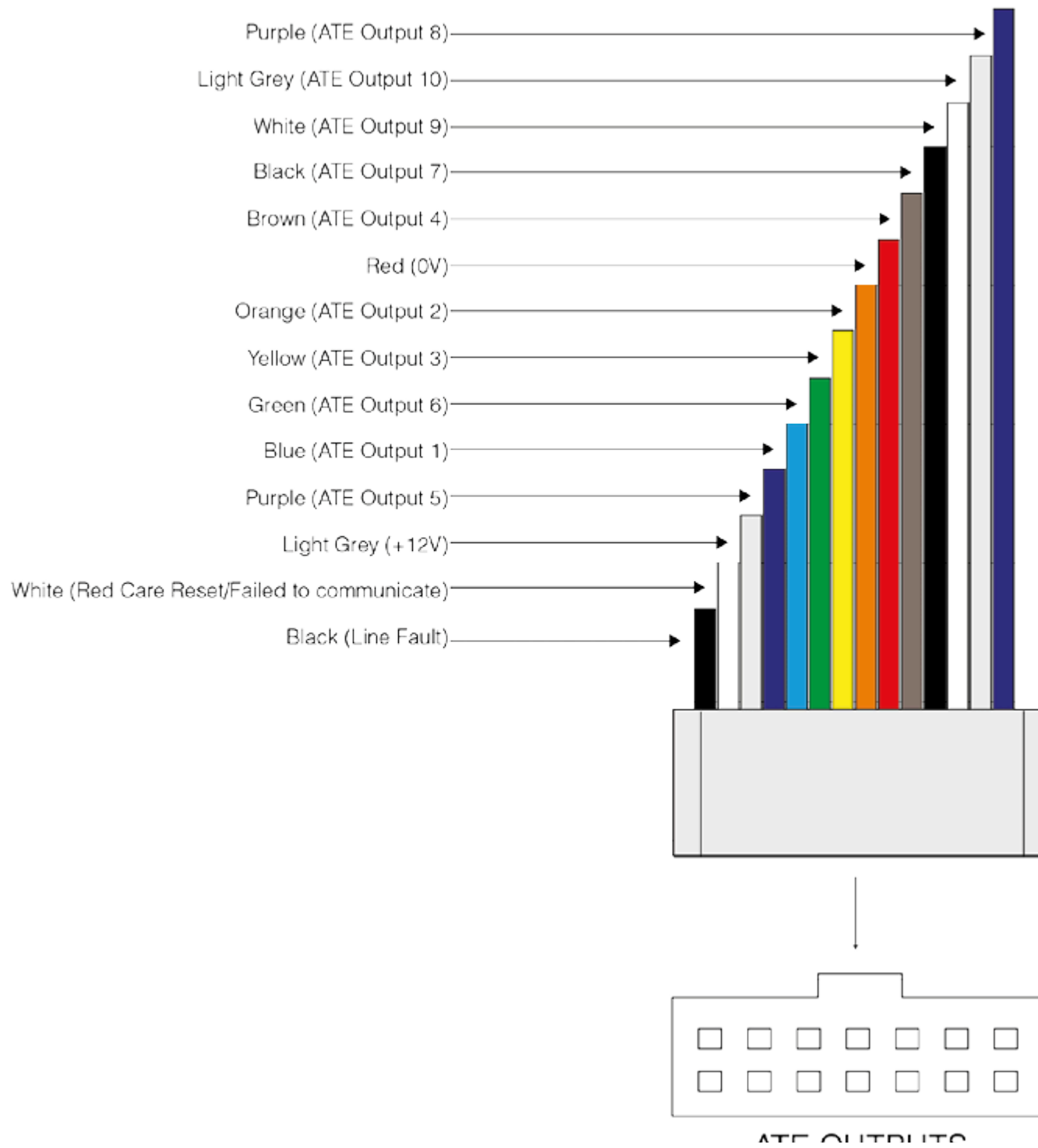

ATE OUTPUTS

The ATE (Alarm Transmission Equipment) outputs are programmed in the Engineer Menu. The programming can be found in 'CHANGE OUTPUTS' then sub menu 'Endstation Outputs'.

Normal Status: 5v

Active Status: 0v

Current: 2mA

PLEASE NOTE: The polarity of the ATE outputs can be changed in the Engineer Menu. The menu option is named 'Invert ATE O/Ps' and can be found as a sub menu in 'SYSTEM OPTIONS' then 'Site Options'. This will invert the polarity of all the programmable ATE outputs, they cannot be done individually.

Power and Battery Connections

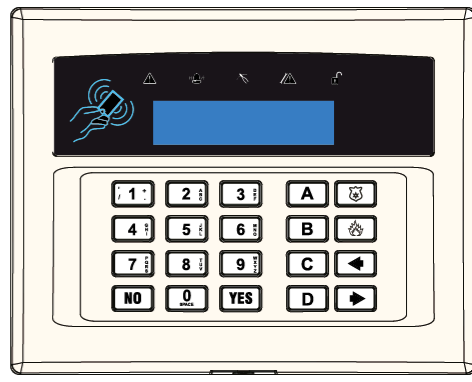
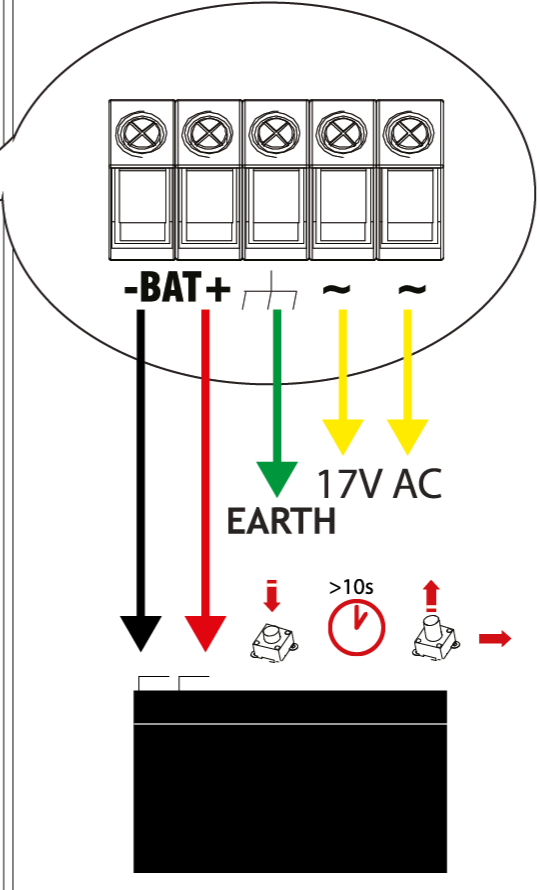
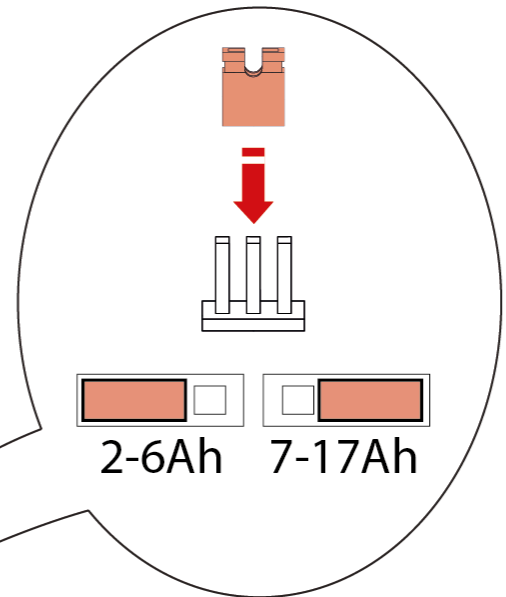
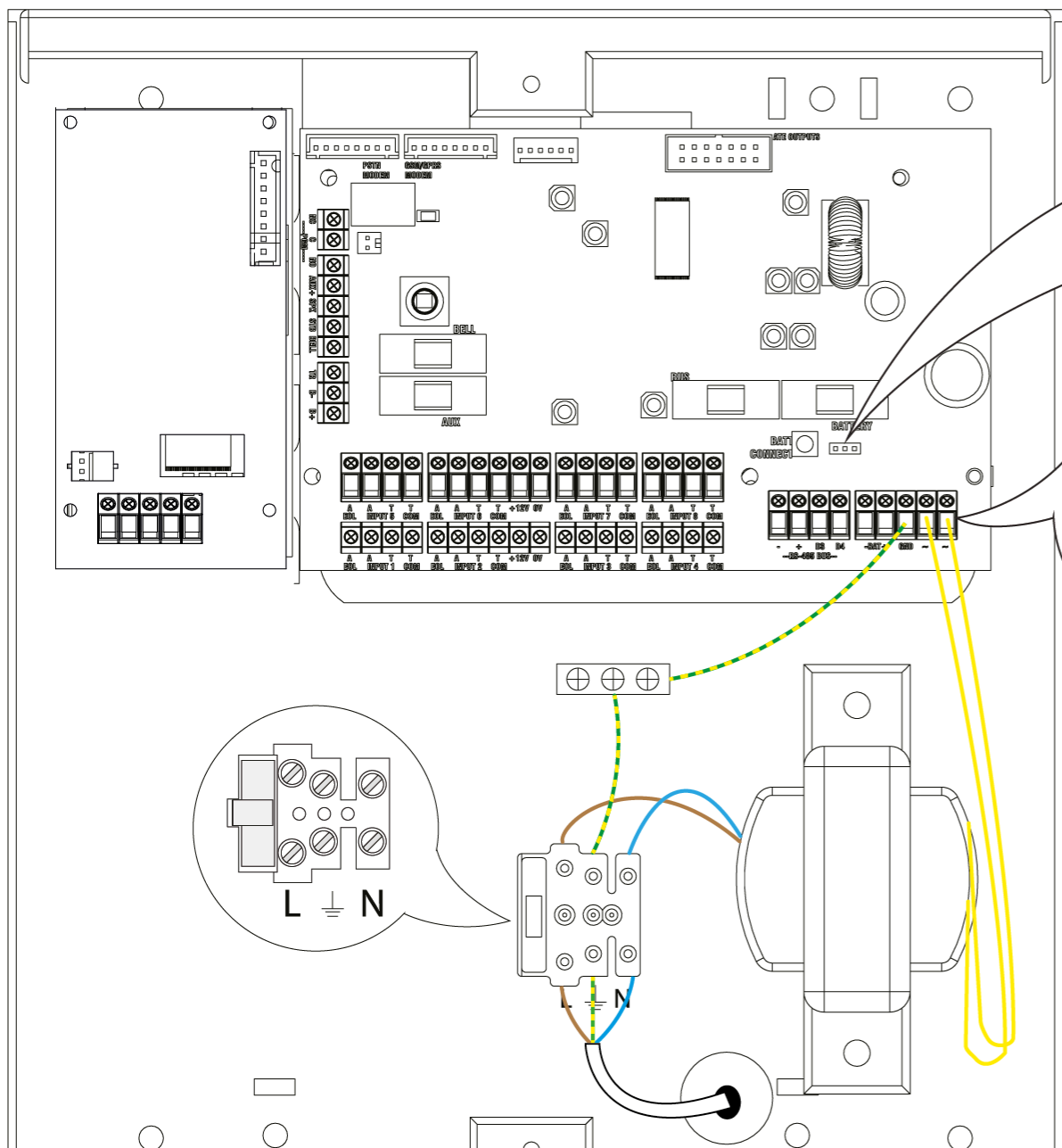



| | | | |
|---------------------------|-------------|-----------------|------------------------------------|
| Panel Power Supply Input | | Nominal | Range |
| Mains Supply Voltage AC | | 230V AC at 50Hz | -15% +10% |
| Transformer Rating | | 18VA | 18V at 1.0A |
| Panel Power Supply Output | | Nominal | Range |
| Output Voltage | | 13.7V DC | 10-15V DC |
| Output Current | Small Metal | 1A Continuous | 1.5A peak, during battery charging |
| | Large Metal | 1.5A Continuous | 2.0A peak, during battery charging |
| Power Supply Type A. | | | |

PLEASE NOTE: Ensure that the 'battery jumper' is in the correct position for the capacity of battery that you have connected – otherwise the panel may under-charge a large battery or over-charge and damage a smaller battery.

485 Bus Wiring

All 485 bus peripherals; LCD keypads, readers, expanders etc. are connected via the D1-, D2+, D3 and D4 terminals. This is an example of what a typical 485 bus may look like.

General Principles:

NOTE 1: No alarm system cable should be run with other cables carrying AC or digital signals.

NOTE 2: The cables should be protected by the use of grommets where appropriate.

NOTE 3: For greater than 1000m range a standard isolated RS485 repeaters required.

NOTE 4: There must be a ferrite bead fitted to one of the outgoing data lines and secured inside the EURO 76 case itself. The Ferrite bead is supplied packaged with a cable-tie which must be used to secure it in the case and prevent it shorting any electrical contacts (Ferrite as shown).

There must also be a ferrite bead fitted to the data wires of a EURO-PROXE (if connected). The Ferrite bead is supplied with the reader.

NOTE 5: If an expansion module with a power supply on board is connected, the D2+ terminal must not be connected between the main bus and module.

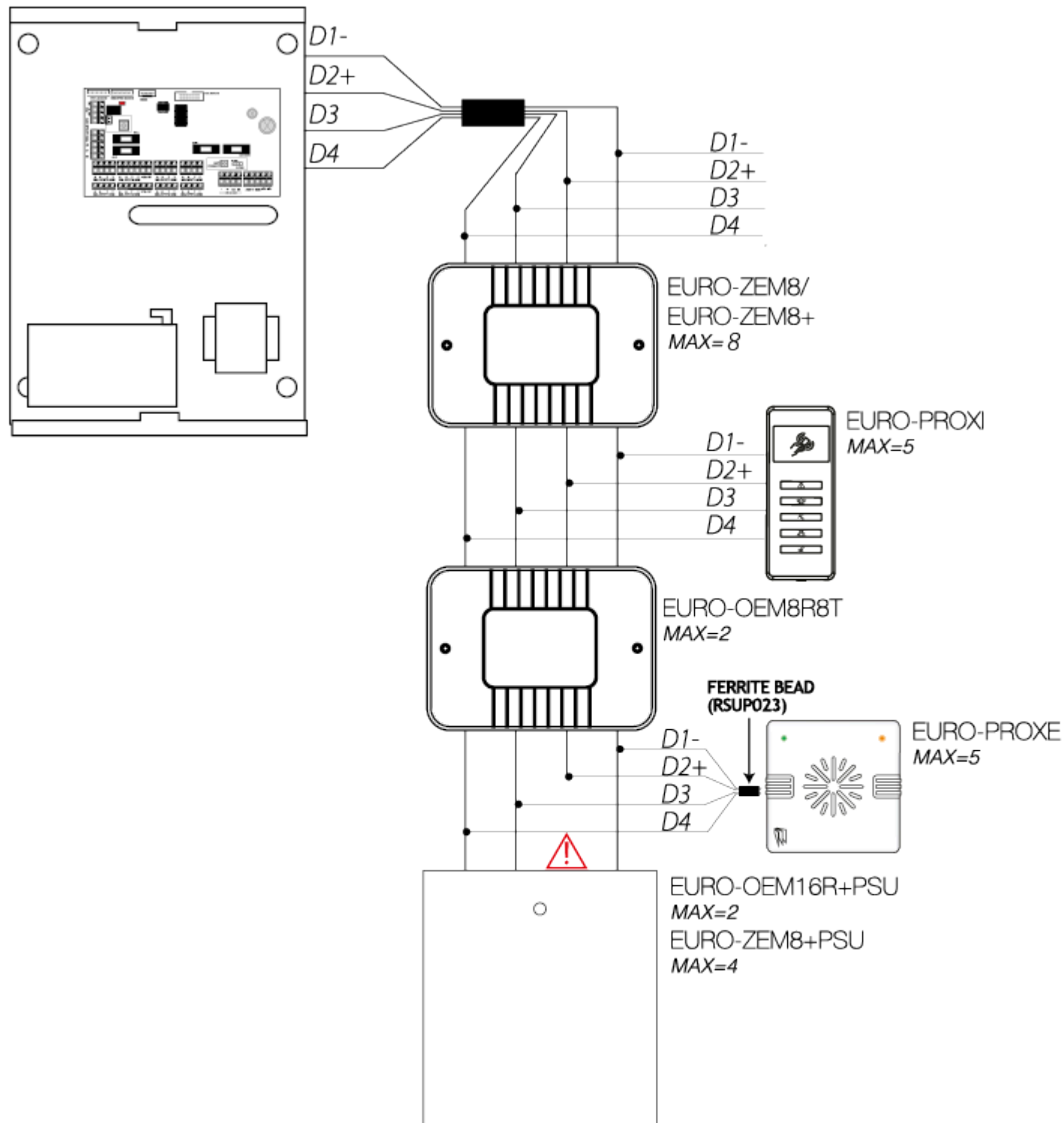

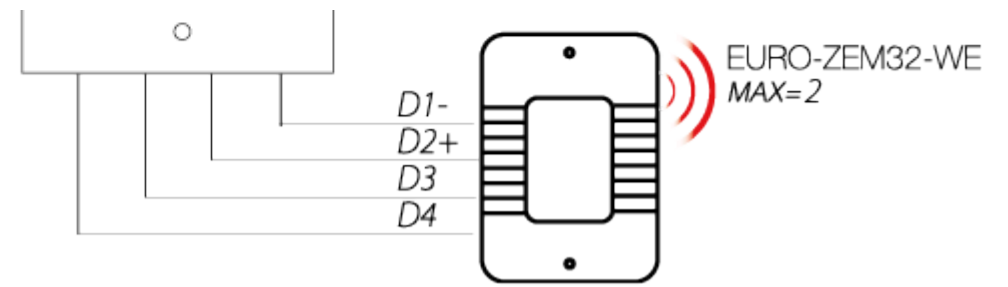

Star and Daisy Chain Wiring

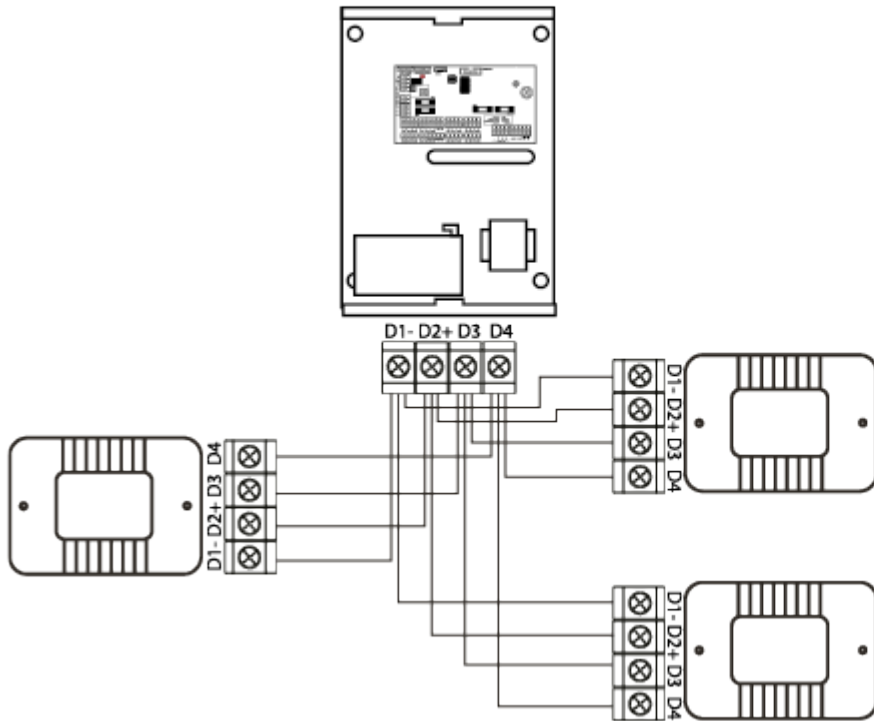

Star Wiring Example

Daisy Chain Wiring Example

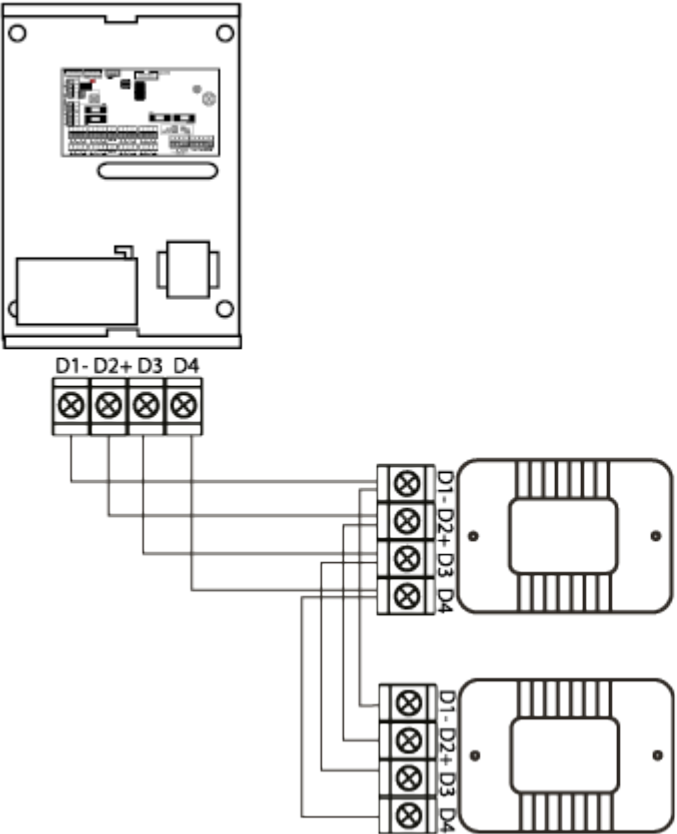

| Cable Type | Screened Cable | Bus Range (m) | Wiring Format | |
|---|---|---------------|-------------------|-------------------|
| | | | Star Wiring Range | Daisy Chain Range |
| 4 core alarm cable | Use this type of cable when the wiring of the 485 bus is located near 230VAC mains power wiring | 300 | 50 m | 1 km |
| 6 core alarm cable (doubling D1 (0v) and D2 (+12V)) | | 1000 | | |
| Twisted Pair | | 1000 | | |

Input Connections

The EURO 76 has options of 4k7/2k2, 4k7/4k7, 1k/1k and wide EOL ranges to choose from. The tolerances for each of these ranges can be found in the technical specification. The 'wide' range has no masking tolerance range. This is added on to the end of the alarm tolerance in order to create a wider alarm tolerance range.

EURO 76 panels are set to 4k7/2k2 at default and would typically used a 2k2 resistor for tamper, 4k7 resistor for alarm and finally a 6k8 resistor for mask.

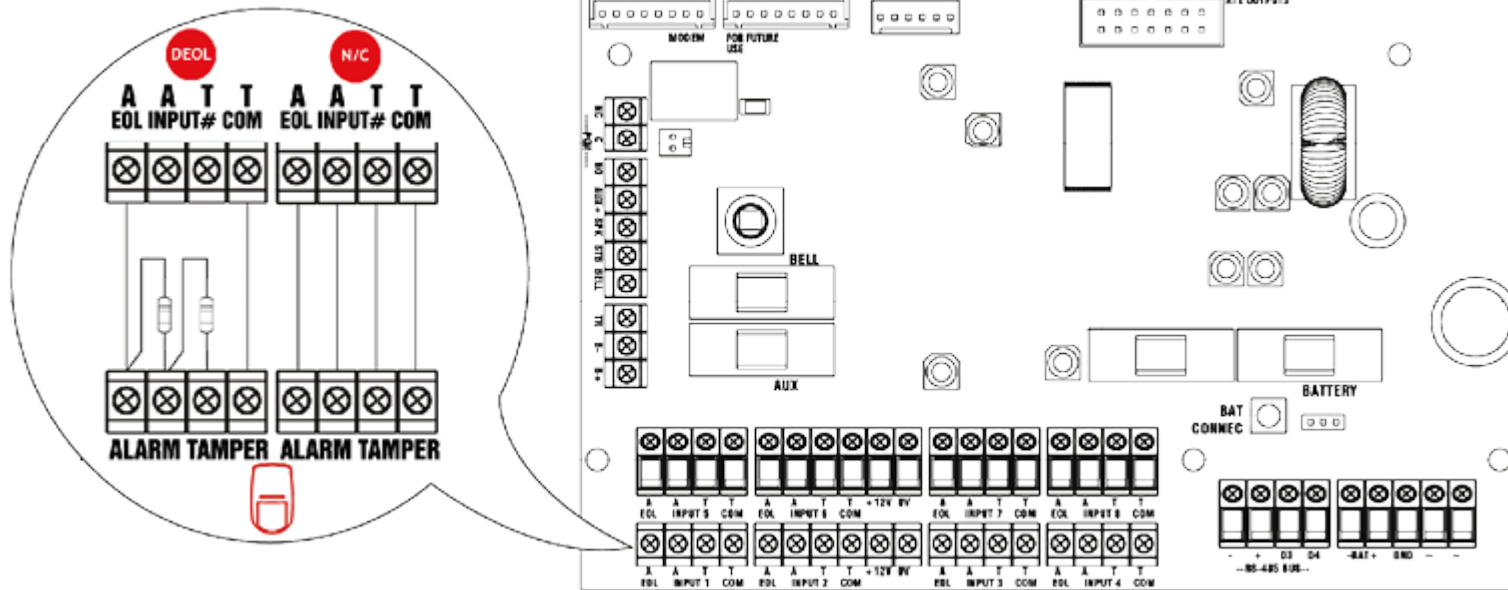

PLEASE NOTE: If 'Normally Closed' (double pole) wiring is utilised, The EOL range must be set to '4k7/2k2' and the EOL mode set to 'DR'. This can be selected in the Engineer Menu in the menu 'CHOOSE MODE'. The 'Diagnostics' on the keypad will show 6K9 when the alarm circuit is open and 2K2 when the alarm circuit is closed. It will show >22k when the tamper circuit is open.



For specific wiring instructions please refer to the installation manual provided with each component that is being wired to the system.

Output (PGM) Connections

Relay and Speaker Output

Normal State: Floating

Active State: 0V

Current: 100mA

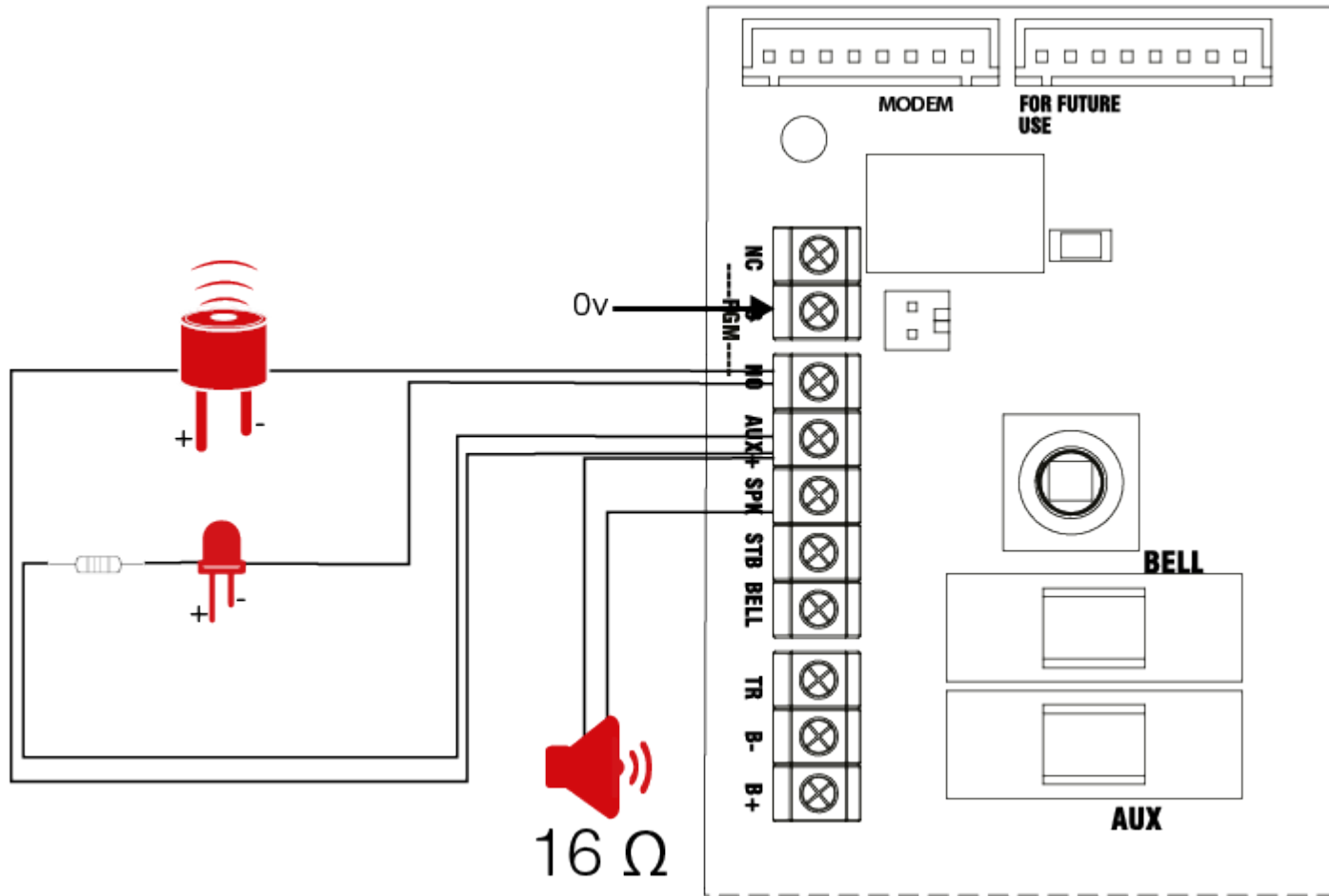

XPGM Outputs

If Inputs 7 and 8 are programmed as 'unused', these inputs can be used as 2 further outputs (known as XPGM1 and XPGM2). Which are programmed in 'CHANGE OUTPUTS' in the Engineer Menu.

Normal State: 12V

Active State: 0V

Current: 50mA switched to 0V

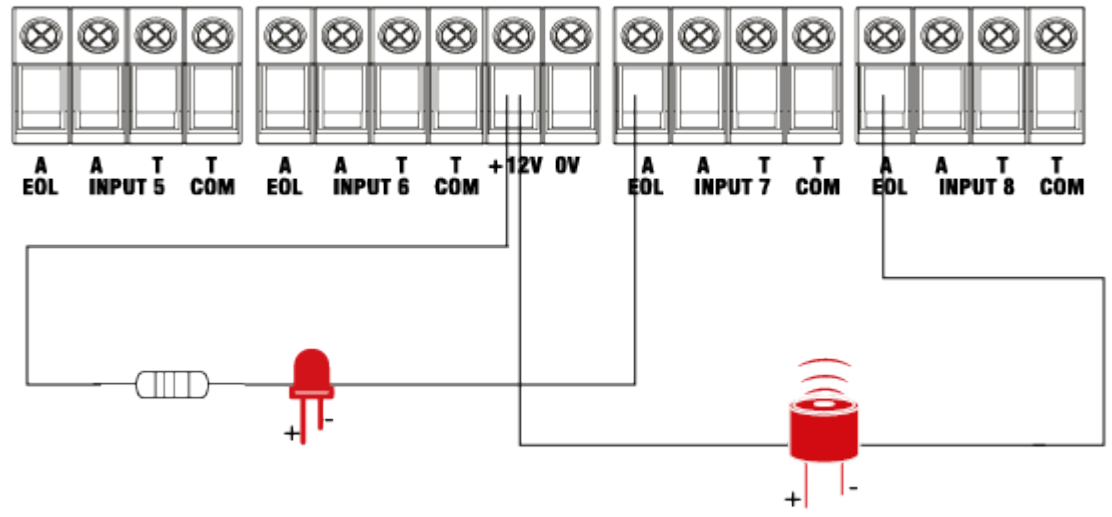

External Sounder Connections

Grade 3 Wiring

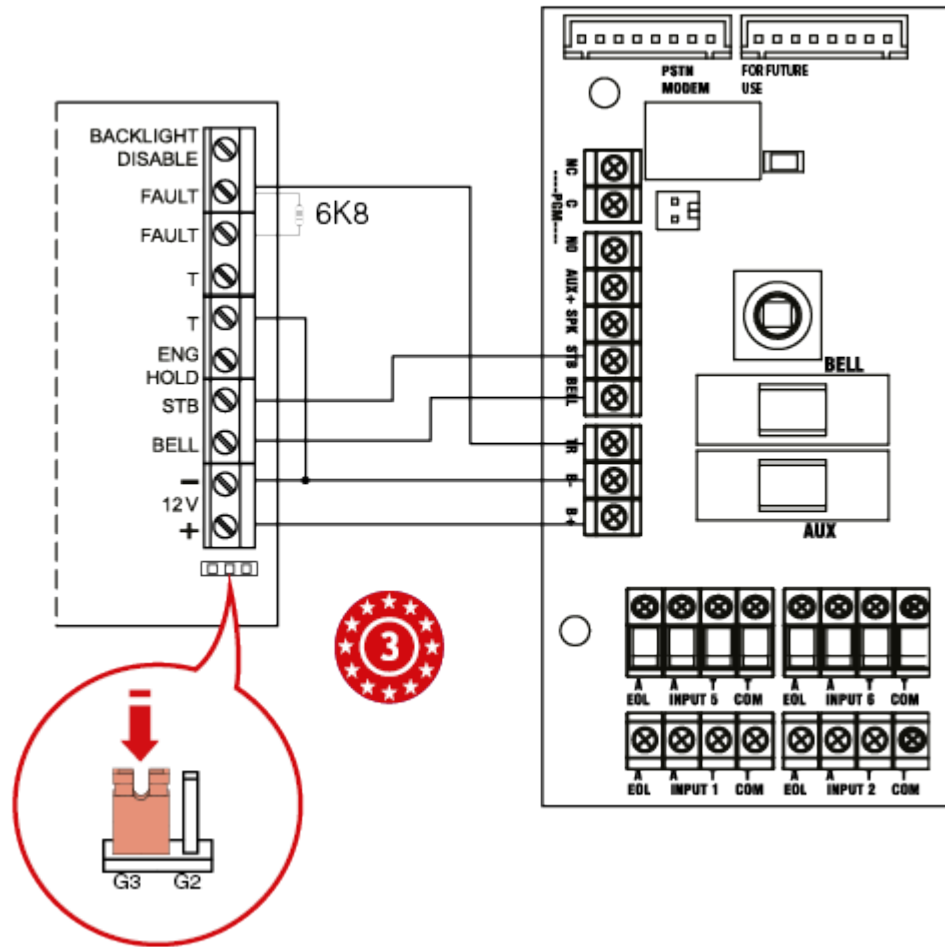

Grade 2 Wiring

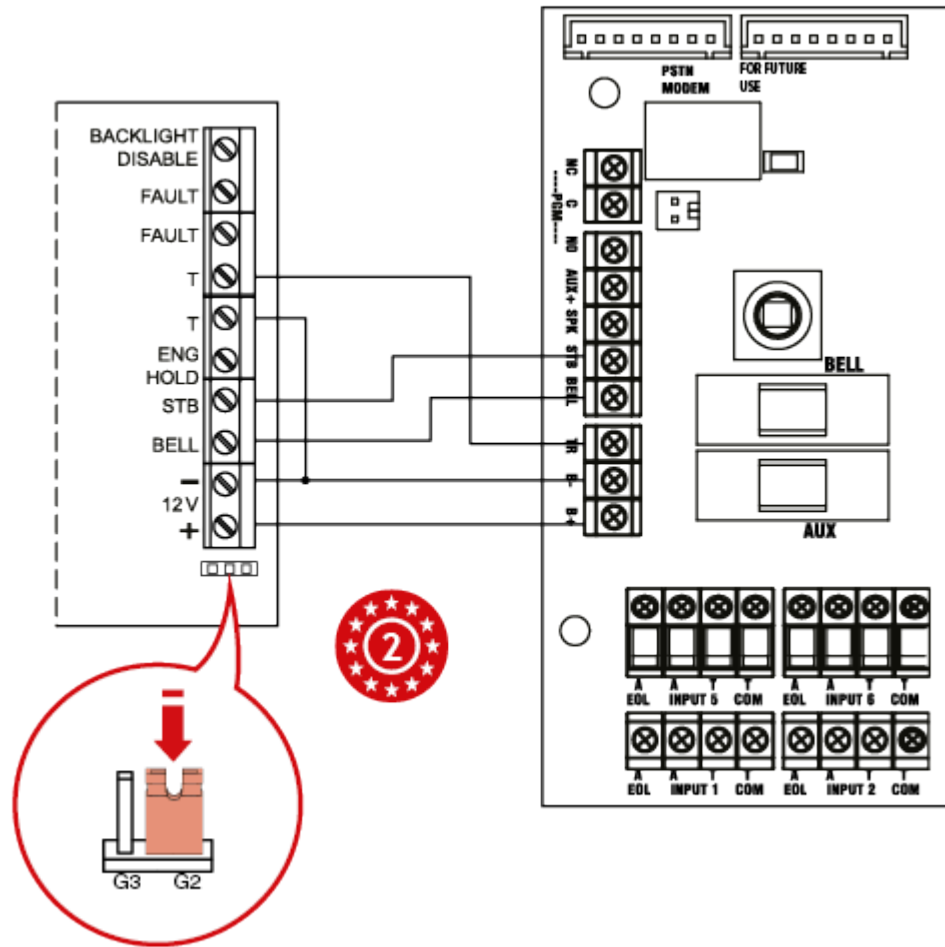

Modems

There are 6 modems there are compatible with the EURO 76 panel. These are:

- DIGI WIFI/XA
- DIGI LAN
- DIGI GPRS

- DIGI GSM
- DIGI 1200
- DIGI PSTN/VOICE

For installation instructions please refer to the manual provided with the modem.

For programming instructions please refer to the 'Communications Guide'.

UDL Software

The EURO 76 control panel can be programmed by the LCD menu or the UDL InSite Software, provided free of charge. It can be downloaded from <https://www.pyronix.co.uk/help-and-support/installers-distributors/insite-software-download/insite-software-download>. The connection between control panel and UDL software can be done in the following ways:

Connecting RS232 to the Panel

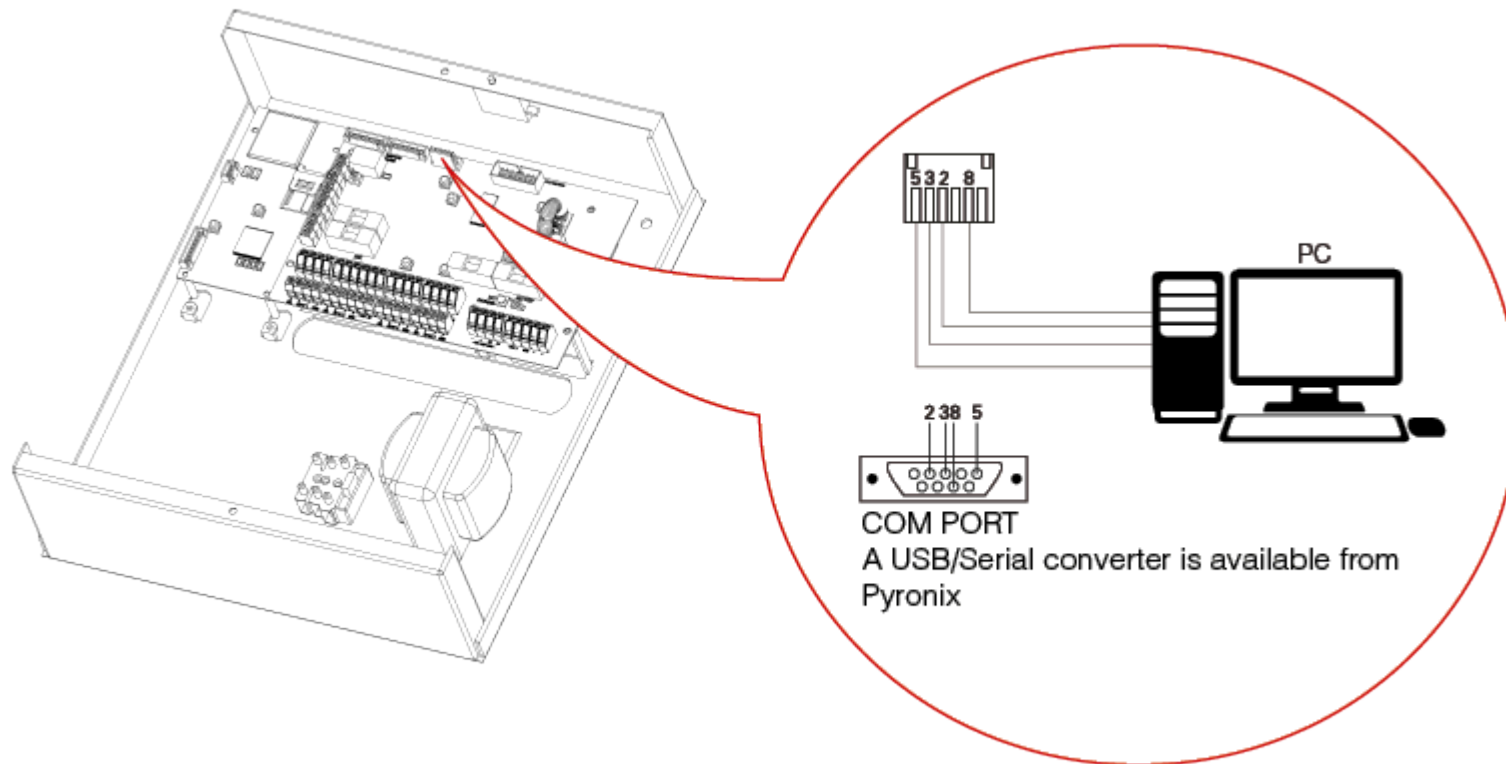

Enter the Engineer Menu.

Scroll the menu (NO button) until the 'SET UP DOWNLOADING?' and press YES.

Choose RS-232 in the "Download by" option – Press YES.

Now on the 'UDL Password' screen, leave 'blank' and Press YES.

Now on the 'Site Name' screen, this is compulsory, make sure that you take a note of it for use later in the InSite software then press YES.

Now on the 'UDL Priority' screen – we recommend setting this to 'High [0]'.

PLEASE NOTE: This prevents HomeContol+ App events / notifications from disconnecting the UDL connection.

Connecting InSite to the Panel via RS232

To setup the COM port associated to 'modem', open the software, click on 'Configuration', choose "Modem Settings" and select "RS-232" option.

Make sure that the serial COM port used by UDL is the set the same in the PC.

PLEASE NOTE: This can be found in the PC via Control Panel > Device Manager > Ports.

Make sure that in the UDL Graphic user interface, the RS-232 icon is green.

Click on 'Roving Dial Customer'.

Set 'Dial Mode' field to 'RS-232'.

Enter the Engineer Code in the 'Engineer Code' field.

Click on 'Dial'.

If connection is successful, the RS-232 icon will become blue.

Setting up a Cloud Connection

Enter the Engineer Menu.

Scroll the menu () until the 'SET UP DOWNLOADING?' and press .

Choose 'Cloud' in the 'Download by' option – Press .

Make a note of your 'System ID' (to enter in the InSite software later) – Press .

Select Security level – for initial connections we recommend [0] (normal) – Press .

Create/enter a system password and take note of it – Press .

Now on the 'Poll Server' screen – select 'Yes [1]' and press .

Now on the 'UDL Password' screen – DO NOT USE – leave blank and Press .

Now on the 'Site Name' screen, this is compulsory, make sure that you take a note of it for use later in the Insite software then press .

Now on the 'UDL Priority' screen – we recommend setting this to 'High [0]'.

PLEASE NOTE: This prevents HomeContol+ App events / notifications from disconnecting the UDL connection.

Connecting InSite to the Panel via the Cloud

Click on 'Roving Dial Customer'.

Click on the 'Dial Out Mode' drop down list and select 'Cloud'.

Enter the 'System ID' of your panel (see 'SET UP DOWNLOADING?' in the panel Engineer Menu).

Enter 'System Password' (see 'SET UP DOWNLOADING?' in the panel Engineer Menu).

Leave the UDL security at 'normal' for initial connection test in 'System Security Level' field.

Enter the Engineer Code as used on the panel you are trying to connect to.

Enter 'Site Name' as entered in panel.

Enter an appropriate panel name into the 'Enter Customer In Database As' field.

PLEASE NOTE: This is just for identification in the InSite software, nothing more.

Click 'Dial'. If connection is successful, the Cloud Icon will become blue, and a dialogue box will appear asking if you would like to create a customer – click 'Yes' to continue.

The EURO 76 control panel is now successfully connected to the Insite UDL software.

EN 50131 Terminology

| | |
|-------------------------------------|---|
| EURO 76 Language | EN50131 Language |
| Set | Set |
| Unset | Unset |
| Day or Unset Mode | Unset State (may be relevant to a specific partition) |
| HU (Hold Up) | Hold Up (HU) |
| Inhibit | Inhibit |
| Unused | Isolated |
| Bell / External Sounder / SAB | External Warning Device (self-powered is assumed) |
| Main Sounder / Speaker | Device combining internal warning device with audible indicator (using different tones and volumes) |
| Prox card, Tag, or Wireless Key Fob | Digital Key |

Access Levels

Level 1: Access by any person; for example the general public.

Level 2: User access by an operator; for example customers (systems users).

Level 3: User access by an engineer; for example an alarm company professional.

Level 4: User access by the manufacturer of the equipment.

PLEASE NOTE: Alarm, tamper and fault indications will automatically be cleared within 3 minutes. If a user has finished viewing the information they can terminate the display instantly by pressing the **YES** key.

Compliance

As per EN 50131-1 the EURO 76 is capable of supporting all conditions A,B and C: –

In Grades 1 & 2 I&HAS when an I&HAS or part thereof is in a set state:

- A) access to the supervised premises or part thereof, via an entry/exit route, shall be prevented, or
- B) opening the door to the entry/exit route shall initiate an entry procedure, or
- C) indication of the set/unset status shall be provided.

In Grades 3 & 4 I&HAS when an I&HAS or part thereof is in a set state:

- A) access to the supervised premises or part thereof, via an entry/exit route, shall be prevented, or
- B) opening the door to the entry/exit route shall initiate an entry procedure.

Warranty

This product is sold subject to our standard warranty conditions and is warranted against defects in workmanship for a period of two years. For further warranty information visit:www.pyronix.com/warranty.

The declaration of conformity and further compliance documentation may be consulted at:www.pyronix.com/product-compliance.php.